

# Installation, Operation & Maintenance



## Progressive cavity pump

F 570, F 580





## Table of contents

<b>1</b>	<b>General information</b> .....	<b>1</b>
1.1	Manufacturer .....	1
1.2	Returns .....	2
1.3	Required and supplementary documentation .....	3
1.4	Presentation of information .....	3
1.4.1	Safety instructions .....	3
1.4.2	Symbols .....	4
<b>2</b>	<b>Safety</b> .....	<b>5</b>
2.1	Intended use .....	5
2.2	Improper use .....	6
2.3	General safety instructions .....	6
2.4	Working in potentially explosive atmospheres .....	7
2.4.1	Explosion protection requirements .....	8
2.5	Qualification of personnel .....	8
2.5.1	Transport personnel .....	8
2.5.2	Assembly personnel .....	8
2.5.3	Operating personnel .....	8
2.5.4	Maintenance personnel .....	9
2.5.5	Qualified electrician .....	9
2.5.6	Manufacturer customer service .....	9
2.5.7	Instructed personnel .....	9
2.5.8	Service personnel .....	9
2.5.9	Qualified personnel .....	10
2.6	Personal protective equipment .....	10
2.7	Behaviour in case of emergency .....	10
2.8	Machine limits .....	11
2.9	Danger area .....	11
2.10	Operating and auxiliary substances .....	11
2.11	Electrical equipment .....	12
2.12	Unauthorised changes .....	12
2.13	Spare parts list .....	12
<b>3</b>	<b>Technical data</b> .....	<b>13</b>
3.1	Marking .....	13
3.1.1	Type code .....	13
3.1.2	Identification .....	15
3.1.3	Ex marking .....	15
3.2	Characteristics .....	15

---

3.2.1	Mechanics.....	15
3.2.2	Performance limits .....	15
3.2.3	Pumping capacity.....	15
3.2.4	Operating and ambient conditions.....	16
3.2.5	Emission sound pressure .....	16
3.2.6	Materials in contact with the medium.....	16
3.2.8	Speed sensor.....	17
3.2.9	Type plate .....	19
<b>4</b>	<b>Functional description.....</b>	<b>20</b>
4.1	Components.....	20
4.1.1	Components of the machine (F 570).....	21
4.1.2	Components of the progressive cavity pump (F 570) .....	22
4.1.3	Components of the machine (F 580).....	23
4.1.4	Components of the progressive cavity pump (F 580) .....	24
4.1.5	Mechanical seal .....	25
<b>5</b>	<b>Transport &amp; storage.....</b>	<b>26</b>
5.1	Safety.....	26
5.2	Transport weight .....	26
5.3	Storage .....	27
5.3.1	Storage conditions .....	27
<b>6</b>	<b>Assembly and installation .....</b>	<b>28</b>
6.1	Safety.....	28
6.2	Assembly between progressive cavity pump and motor .....	29
<b>7</b>	<b>Commissioning .....</b>	<b>33</b>
7.1	Installation of the machine in peripherals .....	33
7.2	Safety.....	35
7.2.1	Before commissioning in potentially explosive atmospheres .....	37
<b>8</b>	<b>Operation and use.....</b>	<b>40</b>
8.1	Safety.....	40
<b>9</b>	<b>Help with faults.....</b>	<b>42</b>
9.1	Safety.....	42
9.2	Troubleshooting .....	43
9.2.1	Fault table .....	44
<b>10</b>	<b>Disassembly and cleaning.....</b>	<b>45</b>
10.1	Safety.....	45
10.2	Preparations.....	46
10.3	Components.....	47
10.4	Assembly of the progressive cavity pump.....	53
<b>11</b>	<b>Maintenance and servicing.....</b>	<b>54</b>

---



## Table of contents

---

11.1	Safety.....	54
11.2	Maintenance schedule .....	56
<b>12</b>	<b>Decommissioning .....</b>	<b>57</b>
12.1	Safety.....	57
<b>13</b>	<b>Disposal.....</b>	<b>58</b>
13.1	Information .....	58
<b>14</b>	<b>Lists .....</b>	<b>59</b>
14.1	List of figures.....	59
14.2	List of tables.....	59
<b>15</b>	<b>Applicable documents .....</b>	<b>60</b>

## 1 General information

The operating instructions enable safe and efficient handling of the progressive cavity pump F 570 (gearbox version) and F 580 (motor flange version).

The operating instructions are part of the progressive cavity pump. They must be kept near at hand for the personnel and be accessible at all times. The personnel must have carefully read and understood these operating instructions before carrying out any work.

If these operating instructions contain documentation from suppliers (as attachment), FLUX-GERÄTE GMBH does not accept any liability for their contents, individual statements, technical data, etc.

© FLUX-GERÄTE GMBH: Technical changes reserved.

These operating instructions may only be reproduced, translated or made available to third parties with the express permission of FLUX-GERÄTE GMBH.

This is a translation of the original operating instructions.

### 1.1 Manufacturer

FLUX-GERÄTE GMBH

Talweg 12

75433 Maulbronn, Germany

Tel. +49 (0)7043 101-0

Fax +49 (0)7043 101-555

E-mail: [export@flux-pumpen.de](mailto:export@flux-pumpen.de)

Internet: <https://www.flux-pumps.com/en-DE/>

### Order and customer service

For your direct contact for ordering and customer service, please refer to the contact section on the FLUX website: <https://www.flux-pumps.com/en-DE/>

## 1.2 Returns

In order for returns to be processed safely and quickly, an RMA form must be requested and sent to FLUX-GERÄTE GMBH together with the RMA number and the product.

The RMA process is described on the FLUX website under the following link:

<https://www.flux-pumps.com/en-DE/service/settlement-of-returns-and-complaints-rma.html>

NOTICE
Products sent to FLUX-GERÄTE GMBH without RMA form and RMA number cannot be accepted.

### 1.3 Required and supplementary documentation

The documents listed in the attachments of these operating instructions (supplier documentation for components, etc.) are part of the scope of delivery and must be observed.

The progressive cavity pump with corresponding motor must not be put into operation before the supplier documentation is available and has been read and understood.

### 1.4 Presentation of information

Uniform safety instructions, symbols, terms and abbreviations are used for simplification and to ensure safe working with these operating instructions. These elements are explained in the following sections for better understanding.

#### 1.4.1 Safety instructions

Safety instructions warn against personal injury or damage to property. The described safety measures must be observed. Safety instructions and warnings in this document identify dangers and risks. They are structured according to ANSI Z535.6-2011 and the ISO 3864 series of standards.

Safety instructions are structured as follows:

 <b>SIGNAL WORD</b>
<b>Type and source of danger</b> Consequences of non-compliance. <ul style="list-style-type: none"><li>➤ Measures for avoidance / prohibitions.</li></ul>

#### Signal words have the following meaning:

- Warning sign: draws attention to the danger.
- Signal word: indicates the severity of the danger.
- Type and source of danger: identifies the causes of the danger.
- Consequences: describes the consequences of non-compliance.
- Measures: lists measures to avoid the danger.

 **DANGER**

This warning indicates a high-risk danger that will result in death or serious injury if not avoided.

 **WARNING**

This warning indicates a medium-risk danger which could result in death or serious injury if not avoided.

 **CAUTION**

This warning indicates a low-risk danger that may result in minor or moderate injury if not avoided.

**NOTICE**

This notice provides information on possible damage to property or the environment that does not result in personal injury.

### 1.4.2 Symbols

Reading of this document is made easier by the use of different symbols and highlighting. Symbols and highlighting have the following meaning:

Table 1: Symbols

Signs	Meaning
■	Instruction for action without sequence
–	List
8. 9.	Instruction for action with sequence
→ ■	Reference to a position (figures in instruction for action)
→ ■	Instruction for action (figures in instruction for action)



## 2 Safety

The progressive cavity pump with corresponding motor was manufactured in accordance with generally recognised rules of technology. Nevertheless, there is a risk of personal injury and damage to property if the safety instructions in these operating instructions are not observed.

The progressive cavity pump with corresponding motor must always only be used in a technically perfect condition and in accordance with its intended use, in a safety-conscious and hazard-conscious manner and in compliance with the operating instructions.

### 2.1 Intended use

The progressive cavity pump is a complete machine in the sense of the Machinery Directive 2006/42/EC.

In the following, the progressive cavity pump without mounted motor is referred to as progressive cavity pump. Assembly between the progressive cavity pump and the motor is referred to as the machine. The progressive cavity pump may only be used in commercial, industrial applications. The progressive cavity pump is technical operating equipment and is not intended for private use.

Progressive cavity pumps are positive displacement pumps. Depending on the version, they are used for pumping low-viscosity to high-viscosity media. They can be used for food and pharmaceutical, cosmetic and chemical products as well as for mineral oil products. Depending on the substance to be pumped and the required performance level, different materials and motors are used.

Each progressive cavity pump can be operated with different motors. The motors available are electric commutator motors, brushless motors, asynchronous motors and air motors. In potentially explosive atmospheres, the used progressive cavity pumps and motors have been tested and approved in accordance with the ATEX directive.

In the EU, progressive cavity pumps and accessories used for pumping foodstuffs comply with the general requirements of Regulation (EC) No. 1935/2004 of 27 October 2004 on materials and articles intended to come into contact with food.

In other countries, the national regulations must be observed. In the USA, the used progressive cavity pumps (and accessories) are FDA-compliant (CFR 21 Part - Food and Drugs) or have 3-A approval.

Depending on the version, the progressive cavity pumps can be used as mobile equipment or installed in systems. For stationary use, the progressive cavity pump must be monitored at all times.

The values and performance limits specified in chapter 3 *Technical data* must be observed.

Intended use also includes having fully read and understood these operating instructions and in particular chapter 2 Safety.

## 2.2 Improper use

A use is considered improper if the machine:

- is used other than described in section 2.1 *Intended use*.
- is used under operating conditions that differ from those described in these operating instructions.
- is exposed to severe weather conditions.

The operator of the machine, not the manufacturer, is liable for any personal injury and damage to property resulting from improper use.

### Foreseeable misuse

- Progressive cavity pumps and additional components must be suitable for the pumped medium.
- The maximum permissible viscosity must be observed.
- Only use media that are allowed to be used in accordance with the specified operating conditions and ambient conditions.
- The progressive cavity pump must not be operated against a closed pressure side.

## 2.3 General safety instructions

- The workplace (including maintenance and service areas) must be sufficiently lit for the work to be performed.
- Check all lines, hoses and screw connections regularly for leaks and externally visible damage! Fix any damage immediately!
- Any instructions of the manufacturers of auxiliary materials and operating materials must be observed, especially the information in the safety data sheets.

## 2.4 Working in potentially explosive atmospheres

- Observe the *Technical Guidelines for Flammable Liquids (TRbF)* as well as explosion protection guidelines for raw materials and the chemical industry as laid down by statutory accident insurance and prevention institutions (BG RCI).
- When pumping flammable media of explosion groups IIA and IIB and temperature classes T1 to T4, only progressive cavity pumps approved for use in category 1 (ZONE 0) may be used.
- Observe the EU type examination certificate or certificate of conformity.
- The progressive cavity pump must not be used in a stationary position in potentially explosive atmospheres.
- Keep possible ignition hazards away from the pump.
- Use a motor protection device including a switch-on lock to prevent unintended automatic start-up (e.g. by switching on the progressive cavity pump by plugging it in).
- For automatic filling, a motor with protection device without switch-on lock can also be used.
- In potentially explosive atmospheres, only explosion-proof motors with approval for category 2 may be used.
- If the motors are operated together with the progressive cavity pump, a comprehensive and clear equipotential bonding must be ensured (see chapter 7.2 *Establishing equipotential bonding*).
- Connect the electric motor with an explosion-proof plug or via an explosion-proof terminal box.
- Arrange the progressive cavity pump in such a way that friction sparks and impact sparks are prevented and safe operation is ensured by the operating conditions.
- Any repairs at explosion-proof progressive cavity pumps and motors may only be carried out by service personnel or an authorised workshop.
- Cleaning and maintenance must not be carried out inside the potentially explosive atmosphere.
- When pumping non-conductive media, there is a possibility that the pumped medium may become electrostatically charged.
- The explosion-proof motor, gearbox and coupling must be outside the movable vessel.
- The hose used must be sufficiently conductive (see IEC-TS-60079-32-1).
- Regularly check all motors according to the applicable/country-specific regulations and accident prevention regulations (in Germany e.g. DGUV regulation 3).
- Handling fluids with low conductivity can lead to static charges. For this reason, check the filling process again (observe IEC-TS-60079-32-1).

### 2.4.1 Explosion protection requirements

**Category 1 (ZONE 0)** The outer part of the progressive cavity pump between the suction opening and the discharge connection.

**Category 2 (ZONE 1)** The outer part of the progressive cavity pump between the discharge connection and the connection part for a motor and the inner part of the progressive cavity pump (when pumping as intended, the inner part is covered by the pumped medium).

## 2.5 Qualification of personnel

Any work on the progressive cavity pump may only be carried out by properly trained, instructed and authorised personnel. The respective authorisations of personnel must be clearly defined. Personnel assigned to work on the progressive cavity pump must have read and understood the entire operating instructions and in particular chapter 2 *Safety* or have been familiarised with the contents in a training course before starting any work.

### 2.5.1 Transport personnel

Transport personnel must:

- be trained in the use of lifting equipment/forklift trucks.
- be able to identify any dangers and take appropriate action.

### 2.5.2 Assembly personnel

Assembly personnel must:

- be appropriately trained (e.g. training as machine fitter).
- be familiar with the structure and function of the progressive cavity pump.
- be able to identify any dangers and take appropriate action.
- be trained in the use of the production equipment.

### 2.5.3 Operating personnel

Users must have been instructed in the operation by the operator. They must be informed about possible dangers during operation and improper behaviour. Tasks that go beyond the activities for which they were instructed may only be carried out by users if the tasks are listed in these operating instructions and if they have been expressly authorised by the operator.

Operating personnel must:

- be familiar with the structure, function, commissioning and operation of progressive cavity pumps.
- be able to identify any dangers and take appropriate action.
- be trained in the use of the production equipment.

### **2.5.4 Maintenance personnel**

Maintenance personnel must:

- be appropriately trained (e.g. industrial technician).
- be familiar with the structure and function of the progressive cavity pump.
- know maintenance, lubrication and/or cleaning points.
- be able to identify any dangers and take appropriate action.
- be trained in the use of the production equipment.

### **2.5.5 Qualified electrician**

Qualified electricians must:

- assess the work assigned to them on the basis of their professional training, experience and knowledge, including the relevant regulations.
- be familiar with the structure and function of the progressive cavity pump.
- be able to identify any dangers and take appropriate action.

### **2.5.6 Manufacturer customer service**

Some work may only be carried out by the manufacturer customer service. Thanks to special professional training, knowledge and experience, the customer service is able to carry out work requiring higher qualifications.

### **2.5.7 Instructed personnel**

Instructed personnel are workers who were demonstrably instructed by the responsible personnel on site about the tasks assigned to them and any potential dangers in case of incorrect behaviour and, if necessary, trained. Instructed personnel must have been instructed about the necessary protective equipment and safety measures. They must be able to work with foresight, recognise dangers and act accordingly. Instructed personnel must not interfere with the operation and function of the progressive cavity pumps.

### **2.5.8 Service personnel**

Service personnel are able to carry out the work assigned to them on the basis of their professional training, experience and knowledge, including the relevant standards and regulations.

Service personnel independently recognise possible dangers, avoid hazards and, in particular, have practical experience and extensive technical knowledge for the potential work to be carried out:

- Transport
- Set-up/installation
- Commissioning
- Maintenance
- Troubleshooting
- Disassembly

### 2.5.9 Qualified personnel

Qualified personnel must have the necessary expertise to inspect work equipment (e.g. tools, devices, machines or installations) on the basis of professional training, professional experience and recent professional activity.

## 2.6 Personal protective equipment

The operator must provide sufficient protective equipment for the personnel. Supervisors must ensure that the protective equipment is being used.

Depending on the kind of work and medium used with the progressive cavity pump, the following personal protective equipment must be worn:

Table 2: Personal protective equipment

Instruction sign	Meaning	Instruction sign	Meaning
	Use protective footwear		Use hand protection
	Use respiratory protection		Use hearing protection
	Use eye protection		

The following instructions must be observed to ensure safety:

- Do not wear loose clothing, jewellery or open long hair.
- Immediately change out of any clothing that has been soiled with highly flammable substances.
- Avoid contact with toxic media, gases, mists, vapours and dusts.

## 2.7 Behaviour in case of emergency

In case of emergency, the following immediate measures must be taken:

- Switch off the machine.
- Secure danger area.
- Report to the person in charge.
- If necessary, alert ambulance service / doctor.

## 2.8 Machine limits

### Temporal limits

The expected service life results from the application, the ambient conditions and the operator's work shift model.

### Spatial limits

The spatial limits result from the space requirements of the machine.

## 2.9 Danger area

Danger areas are reduced as much as possible by the structure of the machine. Depending on the pumped medium, hot surfaces may occur. The peripherals may differ from the following illustration.

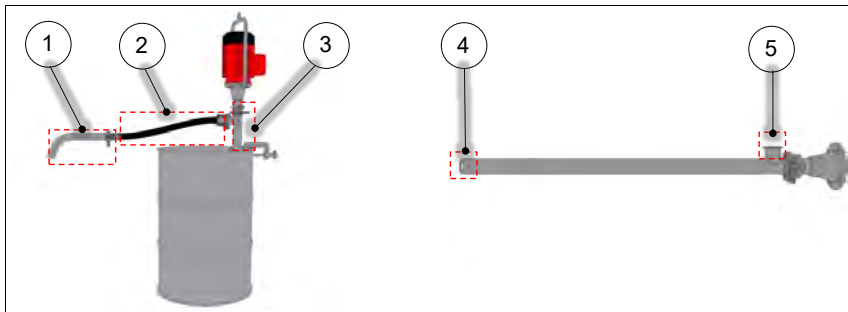

Figure 1: Danger area

Pos.	Meaning	Pos.	Meaning
1	Hot surfaces at the discharge spout	4	Suction opening / rotating rotor
2	Hot surfaces at the hose line	5	Discharge connection / rotating shaft
3	Hot surfaces at the pump tube		

## 2.10 Operating and auxiliary substances

- Observe the safety data sheets of the manufacturers.
- Avoid contact with eyes or skin.
- Avoid inhalation of vapours.
- Immediately collect/bind and properly dispose of spilled or leaked operating and auxiliary substances.
- Keep containers with flammable substances away from heat sources.

## 2.11 Electrical equipment

- Work on electrical equipment may only be carried out by qualified electricians.
- The five safety rules must be observed during all work on electrical components:
  - De-energise
  - Secure against reactivation
  - Verify the absence of voltage
  - Earth and short-circuit
  - Cover or block off any adjacent live parts

## 2.12 Unauthorised changes

Unauthorised changes to the progressive cavity pump are prohibited.

## 2.13 Spare parts list

Despite all the technical innovations, progressive cavity pumps are also subject to wear.

The use of non-original spare parts can, under certain circumstances, have a negative impact on the design properties of the progressive cavity pump and compromise its active and/or passive safety.

Spare parts can be obtained from your FLUX service contact after specification of the serial number.

The assemblies are usually delivered pre-assembled. Not all individual parts of assemblies are available as spare parts.

The spare parts list can be found in the customer area on the FLUX website.



### 3 Technical data

Each progressive cavity pump can be operated with different motors. There are different kinds of motors available. The components of the progressive cavity pumps can be freely configured. In potentially explosive atmospheres, the used components and motors have been tested and approved in accordance with the ATEX directive. Different designs, components and motors are taken into account in the technical data.

#### 3.1 Marking

##### 3.1.1 Type code

The type code is composed as follows:

Table 3: Type code

Position and meaning	Type code	Explanation
1: Type	F 570	Gearbox version (commutator motors, air motors, special asynchronous motors)
	F 580	Motor flange version (asynchronous motors, air motors)
2: Application (Hygiene/FOOD Certificates)	Food	Application in the food sector (compliant with EC 1935/2004 and FDA CFR 21)
	3 A	Special 3-A approval for food/hygiene (compliant with EC 1935/2004 and FDA CFR 21)
		Empty: Industrial application
3: Explosion prevention	Ex	With Ex approval
		Empty: No protection
4: Immersion depth of pump tube	400	[mm]
	700	[mm]
	1000	[mm]
	1200	[mm]
	1500	[mm]
5: Mechanical seal	FKMo	Mechanical seal open FKM
	FKMc	Mechanical seal closed FKM
	FFKMc	Mechanical seal closed FFKM
6: Seal (O-rings)	FKM	Material: FKM
	FFKM	Material: FFKM
	NBR	Material: NBR
7: Suction nozzle	CP	Clamp connection
	SP	Standard suction protection
	ISP	Inliner suction protection
8: Shaft	TS	Torsion shaft
	CS	Joint shaft

Position and meaning	Type code	Explanation
9: Rotor and stator geometry	R17	R17
	R33	R33
	R52	R52
	R83	R83
10: Stator material	NBR	NBR light
	FKM	FKM
	PTFE	PTFE
11: Motor interface	FX	Motor flange (FLUX dimensions)
	G7L	Gearbox i = 7 Anti-rotation device
	G16	Gearbox i = 16
	G16L	Gearbox i = 16 Anti-rotation device
12: Speed sensor		Empty: Without speed sensor
	RC	Speed sensor

**Type code – example:**

**Position:**      1      2      3      4      5      6      7      8      9      10      11      12

**Abbreviation:**    F 580 Food Ex 1500 FFKMcFFKM ISP TS R83 PTFE G16L RC

## Technical data

### 3.1.2 Identification

Table 4: Marking – Identification

Designation	Value
Machine designation	VISCOPOWER
Designation of versions	F 570 / F 580
Year of introduction	2022

### 3.1.3 Ex marking

The Ex marking of pump types F 570 ..EX.. and F 580 ..EX.. is: II 1/2 G Ex h IIB T4...T3 Ga/Gb.

## 3.2 Characteristics

The technical data for separate equipment and purchased parts can be found in the associated technical documentation.

### 3.2.1 Mechanics

Table 5: Characteristics – Mechanics

Designation	Value
Length (F 570 / F 580)	1720 mm* / 1748 mm*
Diameter around pump axis (F 570 / F 580)	Approx. 175 mm* / approx. 175 mm*
Weight (F 570 / F 580)	9 kg* / 9.8 kg*

\*At 1500 mm immersion depth (maximum dimensions and weight)

### 3.2.2 Performance limits

Table 6: Characteristics – Mechanics

Version	Type code	Max. speed	Max. torque
Motor flange version	FX	1000 rpm	20 Nm
Gearbox version i =7	G7L	7000 rpm	2.85 Nm
Gearbox version i =16	G16 / G16L	16000 rpm	1.25 Nm

### 3.2.3 Pumping capacity

Table 7: Characteristics – Pumping capacity

Rotor and stator geometry	Volume per revolution*
R17	17 ml
R33	33 ml
R52	52 ml
R83	83 ml

\*The actual pumping flow depends on the pump, the motor, the medium and the operating conditions and can therefore deviate strongly from the specified delivery volume.

### 3.2.4 Operating and ambient conditions

Table 8: Characteristics – Operating and storage conditions

Designation	Value
Min. ambient temperature	-20 °C
Max. ambient temperature	40 °C
Min. fluid temperature	-10 °C*
Max. fluid temperature	100 °C*
Min. fluid temperature (Ex range)	0 °C
Max. fluid temperature (Ex range)	40°C for temperature class T4 > 40°C to 90°C for temperature class T3
Max. operating pressure (open mechanical seal)	10 bar
Max. operating pressure (closed mechanical seal)	15 bar

\*Depending on the material of the stator

### 3.2.5 Emission sound pressure

The sound pressure level depends on the motor used and can vary depending on the design and load of the progressive cavity pump. The following table only specifies the highest measured values.

Table 9: Characteristics – Emission sound pressure

Version	Motor	Value
Gearbox version, i =16	Commutator motor	71 dB (A) - 79 dB (A)
Gearbox version, i =7	Asynchronous motor	<70 dB (A)
Motor flange version	Asynchronous motor	< 70 dB (A)
Gearbox version, i =16	Air motor	83–90 dB (A)* <sup>1</sup> / 95 dB (A)* <sup>2</sup>
Motor flange version	Air motor	89 dB (A)* <sup>1</sup> /78 dB (A)* <sup>3</sup>

\*<sup>1</sup> Sound pressure level dB(A) measured with standard sound absorber

\*<sup>2</sup> Sound power level LWA in dB(A)

\*<sup>3</sup> Sound pressure level dB(A) measured with 4 m exhaust air hose 3/8" and fine filter sound absorber FS 3



### 3.2.6 Materials in contact with the medium

Table 10: Materials

Component	Material
Pump tube	Stainless steel 1.4404 (316L)
Rotor	Stainless steel 1.4571 (316Ti)
Stator	PTFE / NBR / FKM
O-rings	NBR / FKM / FFKM
Pump shaft	1.4404 (316L)
Joint shaft	1.4305 (303)

### 3.2.8 Speed sensor

The speed sensor is suitable for use with FLUXTRONIC®.

 <b>DANGER</b>	
	<p><b>Explosion and fire hazard</b></p> <p>Risk of death from explosions and fires when working in potentially explosive atmospheres.</p> <ul style="list-style-type: none"> <li>➤ Read chapter 2.4 <i>Working in potentially explosive atmospheres</i>.</li> <li>➤ The speed sensor must always be operated via intrinsically safe devices.</li> </ul>

<b>NOTICE</b>
Mounting on a ferritic base affects the switching behaviour.

### General information

Table 11: Speed sensor – General information

Designation	Value
Inductive and capacitive loads	It is essential to provide contact protection
Pulses per revolution	4
EC conformity 2014/35/EU Low Voltage Directive	CE

### Electrical data

Table 12: Speed sensor – Electrical data

Designation	Value
Output type	Reed contact
Switching function	1 NO contact
Max. switching capacity	10 VA
Max. switching current	0.5 A
Max. transport current	1.0 A
Max. switching voltage	200 V
Max. contact resistance	0.1 Ω

**Mechanical data**

Table 13: Speed sensor – Mechanical data

Designation	Value
Housing material	X8CrNiS18-9 (1.4305)
Hexagon nut	DIN 936, low shape, stainless steel A2
Casting	Epoxy resin clear
Protection class	IP65 according to DIN VDE 0470 T1

**Thermal data**

Table 14: Speed sensor – Thermal data

Designation	Value
Min. use and storage temperature	- 30 °C
Max. use and storage temperature	+ 80 °C

**Connection**

Table 15: Speed sensor – Connection

Designation	Value
Plug, max. current 4 A	3-pole built-in plug Ø 8 mm
Snap-on contact carrier	PA6-3-T sw
Contacts	CuZn gold-plated
Protection class	IP67, only when plugged in
Insulation resistance	$\geq 10^9 \Omega$
Max. voltage	60 V
Max. current	4 A



Figure 2: Wiring diagram (unactuated)

### 3.2.9 Type plate

The contents of the type plate depend on the respective version.

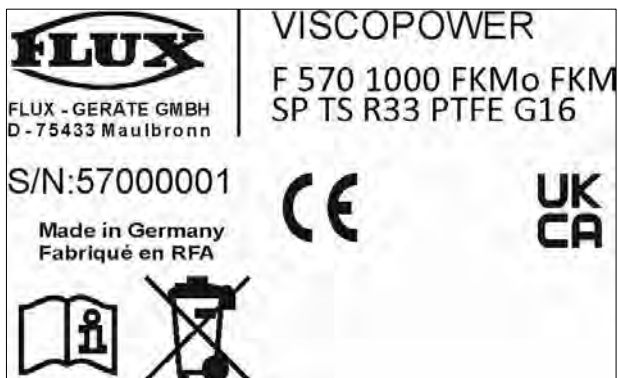

Figure 3: Type plate (symbol image)

## 4 Functional description

Depending on the version, progressive cavity pumps are used for pumping low-viscosity to high-viscosity media. They can be used for food and pharmaceutical, cosmetic and chemical products as well as for mineral oil products. Depending on the substance to be pumped and the required performance level, different materials and motors are used. Each progressive cavity pump can be operated with different motors.

### 4.1 Components

Progressive cavity pumps consist of the following freely configurable or interchangeable modules:

- Motor connection
- Pump shaft
- Pump tube
- Rotor
- Rotor shaft (only with 3-A approval, replaces rotor and pump shaft)
- Stator
- Stator housing
- Seals/O-rings
- Mechanical seals

Due to the modular principle, the components can differ in size and design. In the following, the differences between the gearbox version F 570 and the motor flange version F 580 are illustrated in an example on the basis of an immersion depth of 1000 mm. Both variants are also available in a version for horizontal use, which only differ in design of peripherals and a clamp connection at the stator housing. The fixation in horizontal position is realised by means of a pump trolley or console and is not considered in the following.



### 4.1.1 Components of the machine (F 570)

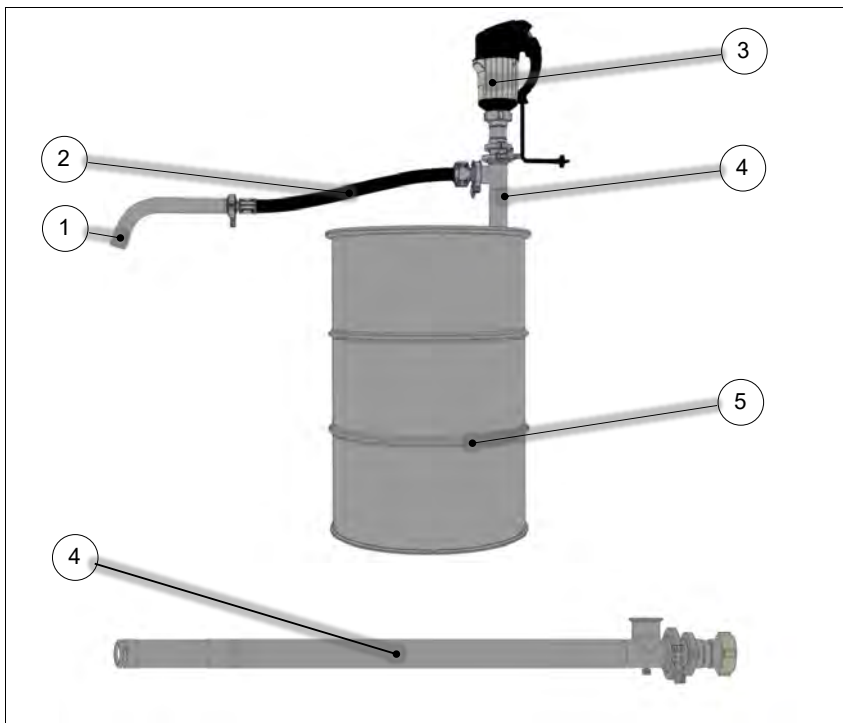

Figure 4: Peripheral components (symbol image)

Pos.	Meaning	Pos.	Meaning
1	Outlet	4	Progressive cavity pump
2	Hose line	5	Drum
3	Commutator motor		

#### 4.1.2 Components of the progressive cavity pump (F 570)

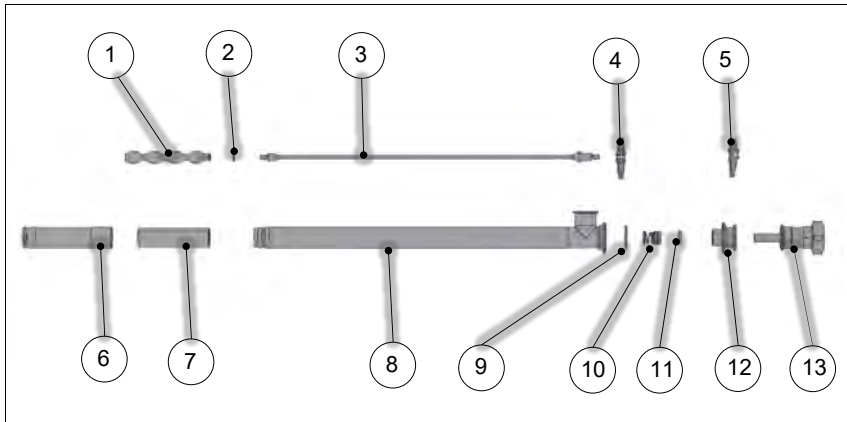

Figure 5: Components of the progressive cavity pump

Pos.	Meaning	Pos.	Meaning
1	Rotor	8	Pump tube
2	O-ring between rotor and pump shaft	9	O-ring between pump tube and seal carrier
3	Pump shaft	10	Mechanical seal (open)
4	Clamp connection between seal carrier and pump tube	11	Counter ring of mechanical seal
5	Clamp connection between seal carrier and motor connection	12	Seal carrier
6	Stator housing	13	Motor connection (gearbox)
7	Stator		

### 4.1.3 Components of the machine (F 580)

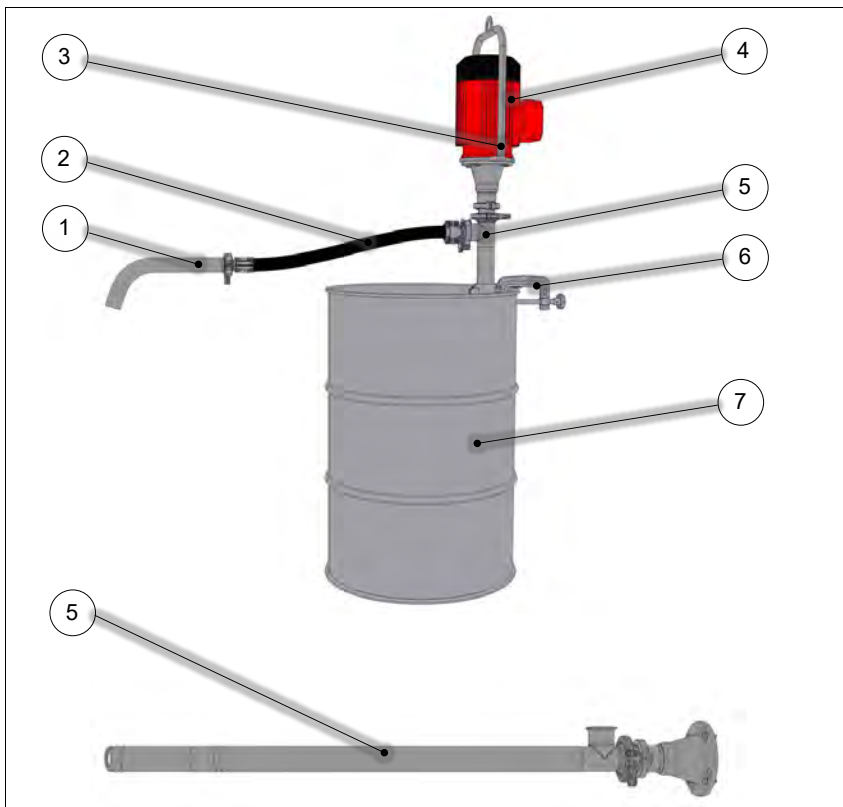

Figure 6: Peripheral components (symbol image)

Pos.	Meaning	Pos.	Meaning
1	Outlet	5	Progressive cavity pump
2	Hose line	6	Clamping device
3	Retaining bracket	7	Drum
4	Asynchronous motor		

#### 4.1.4 Components of the progressive cavity pump (F 580)

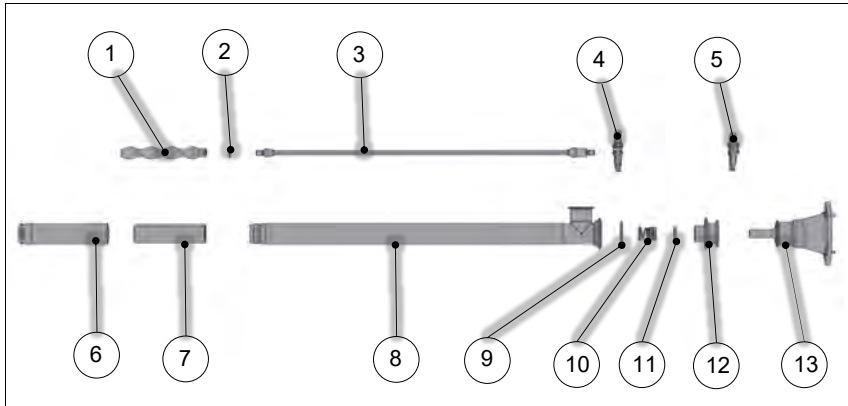

Figure 7: Components of the progressive cavity pump

Pos.	Meaning	Pos.	Meaning
1	Rotor	8	Pump tube
2	O-ring between rotor and pump shaft	9	O-ring between pump tube and seal carrier
3	Pump shaft	10	Mechanical seal (open)
4	Clamp connection between seal carrier and pump tube	11	Counter ring of mechanical seal
5	Clamp connection between seal carrier and motor connection	12	Seal carrier
6	Stator housing	13	Motor connection (motor flange)
7	Stator		

## Functional description

### 4.1.5 Mechanical seal

The mechanical seal is available as open and a closed version.

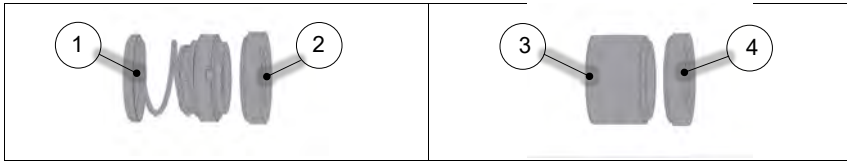

Figure 8: Mechanical seals

Pos.	Meaning	Pos.	Meaning
1	Open mechanical seal	3	Closed mechanical seal
2	Counter ring	4	Counter ring

## 5 Transport & storage

Transport of the product is already completed at the time of placing it on the market and is not considered in these operating instructions. The safety instructions in this chapter only refer to the progressive cavity pump without motor and peripherals.

### 5.1 Safety

#### WARNING

##### Falling loads

Due to the weight of the progressive cavity pump, unexpected load reactions may occur when it is lifted for positioning with the consequence of serious personal injury.

- Do not stand or walk under suspended loads.
- The following personal protective equipment must be used:
  - Hand protection
  - Protective footwear
  - Head protection
- The progressive cavity pump may only be transported by qualified and authorised transport personnel.
- Check the progressive cavity pump for transport damage.
- Avoid electrostatic charging during transport in the Ex-protected area.
- The progressive cavity pump must be cleaned before each internal transport.
- Do not transport the progressive cavity pump together with installed peripherals and mounted motor.
- For portable use, be sure to use a safe, explosion-proof carrying aid.

### 5.2 Transport weight

Table 16: Transport weight

Component	Mass/weight
Progressive cavity pump F 570	9 kg*
Progressive cavity pump F 580	9.8 kg*

\*At 1500 mm immersion depth (maximum weight)

### **5.3 Storage**

Residues of conveyed media must be completely removed so that they do not harden and become stuck in the progressive cavity pump.



#### **5.3.1 Storage conditions**



- Suspend the progressive cavity pump from a fixture.
- Do not store outdoors.
- Store in a dry and dust-free environment.
- Protect from mechanical shocks.
- The recommended storage temperature is between +12 °C and +15 °C.

## 6 Assembly and installation

Assembly includes the connection between the progressive cavity pump and the motor as well as the installation in peripherals.

### 6.1 Safety

 <b>DANGER</b>	
	<p><b>Explosion and fire hazard</b></p> <p>Risk of death from explosions and fires when working in potentially explosive atmospheres.</p> <ul style="list-style-type: none"> <li>➤ Read chapter 2.4 <i>Working in potentially explosive atmospheres</i>.</li> </ul>

 <b>DANGER</b>	
 	<p><b>Vapours hazardous to health</b></p> <p>Depending on the pumped medium, there is a risk of death due to hazardous gases.</p> <ul style="list-style-type: none"> <li>➤ Use respiratory protection.</li> <li>➤ Use eye protection.</li> </ul>

 <b>WARNING</b>	
<p><b>Falling loads</b></p> <p>Due to the weight of the machine, unexpected load reactions may occur when it is lifted for positioning with the consequence of serious personal injury.</p> <ul style="list-style-type: none"> <li>➤ Do not stand or walk under suspended loads.</li> </ul>	

- The following personal protective equipment must be used:
  - Hand protection
  - Protective footwear
  - Head protection
- The work may only be carried out by qualified and authorised assembly personnel.
- Observe assembly drawings and associated technical data.
- Make sure that the components are properly secured to their base.
- Check all screw connections for secure fitting.



## 6.2 Assembly between progressive cavity pump and motor

### Connecting the progressive cavity pump F 570 and motor

1. Place the motor at the centring at the gearbox.



2. Tighten the union nut.

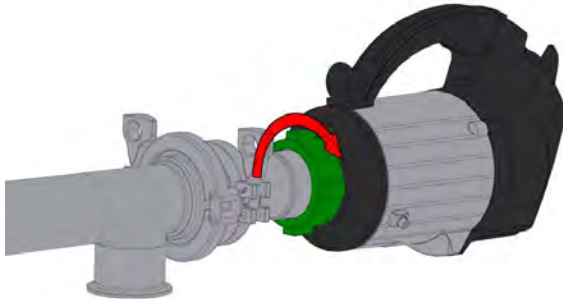

→ The progressive cavity pump and the motor are now connected to each other.

**Connecting the progressive cavity pump F 580 and asynchronous motor or air motor**

As the motor is heavy, it can be attached by means of lifting gear via a retaining bracket.

**WARNING****Falling loads**

Due to the weight of the motor, unexpected load reactions may occur when it is lifted for positioning with the consequence of serious personal injury.

- Do not stand or walk under suspended loads.

1. Position the motor in the retaining bracket.

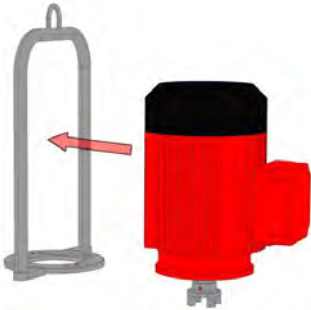

2. To attach the retaining bracket to the motor, tighten the four countersunk screws at the bottom of the retaining bracket.

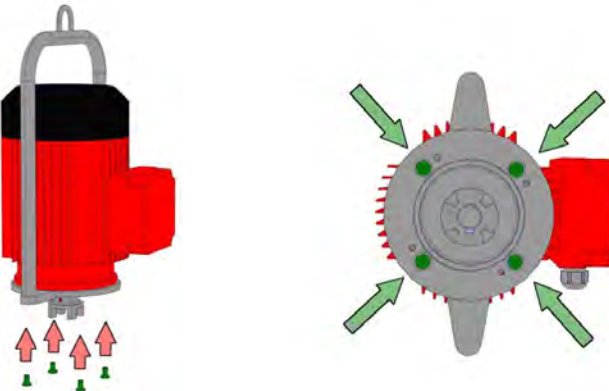

3. Suspend the motor together with the retaining bracket at the hook of a suitable hoist.



4. Lightly tighten the four hexagonal screws in the thread of the retaining bracket.

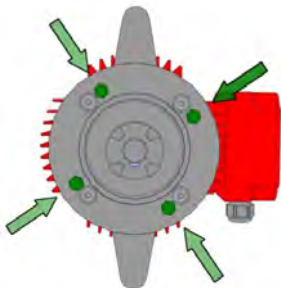

- Engage the progressive cavity pump with the grooves at the hexagonal screws and turn the progressive cavity pump in the groove in such a way that its weight is supported by the hexagonal screws.

**NOTICE**

The hexagonal screws must be fitted together with the corresponding washers.

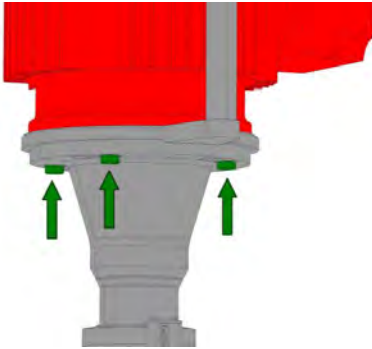

- Tighten the hexagonal screws with a torque of 20 Nm.  
→ The progressive cavity pump and the motor are now connected to each other.

## 7 Commissioning

### 7.1 Installation of the machine in peripherals

Installation of the machine in peripherals is almost identical for F 570 and F 580. Due to the higher weight of the motors, a suitable lifting gear is required for the motor flange version. Both variants are also available in a version for horizontal use, which only differ in design of peripherals. The fixation in horizontal position is realised by means of a pump trolley or console and is not considered in the following.

#### WARNING

##### Falling loads

Due to the weight of the machine, unexpected load reactions may occur when it is lifted for positioning with the consequence of serious personal injury.

- Do not stand or walk under suspended loads.

#### Preparing the drum

1. Secure the drum against falling over.
2. Attach the clamping device to the drum and tighten the star knob screw.

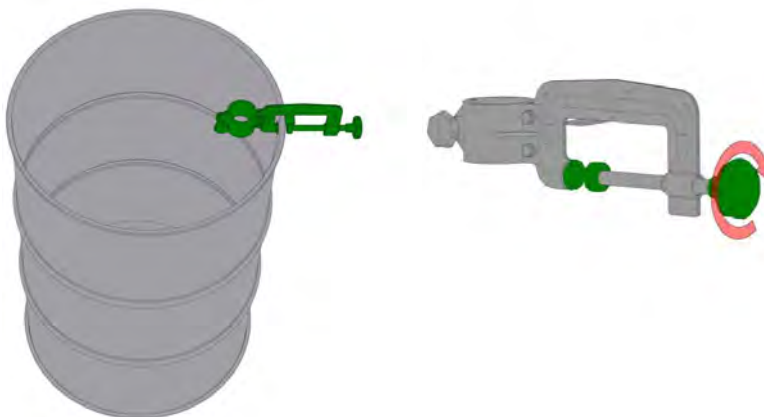

→ The drum is now prepared.

**Setting up the progressive cavity pump in a drum****NOTICE**

To prevent individual parts from falling into the drum, carry out the following steps before positioning the progressive cavity pump over the drum.

1. Attach the hose line with a suitable clamp to the discharge connection of the progressive cavity pump.



2. Guide the pump tube through the opening of the clamping bracket and tighten it securely.

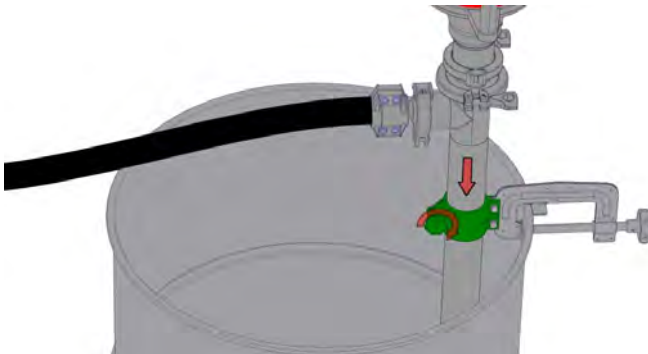

→ The machine is now installed in the peripherals.

## 7.2 Safety

### DANGER



#### Explosion and fire hazard

Risk of death from explosions and fires when working in potentially explosive atmospheres.

- Read chapter 2.4 *Working in potentially explosive atmospheres*.

### DANGER



#### Vapours hazardous to health

Depending on the pumped medium, there is a risk of death due to hazardous gases.

- Use respiratory protection.
- Use eye protection.



### WARNING



#### Hot surfaces

Depending on the pumped medium, there is a risk of burns on hot surfaces of the progressive cavity pump and peripherals.

- Use heat-resistant hand protection.

### WARNING



#### Running shaft and running rotor

Risk of cutting and injury from the running shaft and rotor.

- Do not reach into the suction opening or the discharge connection of the progressive cavity pump!

 **WARNING****Free-running drive shaft**

Risk of drawing in and injury due to free-running drive shaft of the motor.

- Do not operate the motor without the progressive cavity pump!
- Only switch on the machine if it has been properly installed in the peripherals.

 **WARNING****Unpredictable start-up of the motor**

Risk of injury due to medium spraying out.

- Secure the motor against unintentional start-up.
- Use eye protection.

- The following personal protective equipment must be used:
  - o Hand protection
  - o Protective footwear
  - o Eye protection (depending on the pumped medium)
  - o Hearing protection (depending on emission sound pressure)
  - o Respiratory protection (depending on the pumped medium)
- The machine may only be put into operation by qualified and authorised operating personnel.
- Secure the machine against unintended activation while work is being carried out.
- Before daily commissioning, make sure that the machine is in a proper working condition. Report any faults, damage or changes to the machine to the operator immediately.
- Compare the operating voltage of the motor with the specifications on the type plate.
- For air motors, do not exceed the maximum operating pressure of 6 bar and use the maintenance unit.
- For air motors, set the speed via a ball valve in the compressed air supply. Slowly bring the air motor up to working speed.
- The motors must not exceed a torque of 20 Nm.
- Before connecting the mains plug, set the on/off switch to "0" (stop).
- In case of air motors, close the valve before connecting the mains plug.
- Do not exceed the maximum speed of 1000 rpm.
- When using asynchronous motors, check the direction of rotation of the motor (direction of rotation according to indicator on the seal carrier).
- Before use, attach the equipotential bonding conductors to the progressive cavity pump, motor and container.
- Do not switch on the machine before the progressive cavity pump is in the medium.
- Three-phase motors may only be operated with upstream motor protection switch.



- Installation work at electric motors may only be carried out by qualified electricians.
- Observe the maximum operating pressure and operating temperature.
- The screw connections between the progressive cavity pump and the motor must be securely tightened.
- At the F 580, correct fitting of the claw coupling must be checked (see applicable documents *Assembly sheet - Coupling on motor*).
- The power supply must be equipped with a residual-current circuit breaker.

### 7.2.1 Before commissioning in potentially explosive atmospheres

#### NOTICE

If the socket outlet or terminal box is clearly located outside the potentially explosive atmosphere, explosion protection at the connection point can be dispensed with.

- When pumping flammable media of explosion groups IIA and IIB and temperature classes T1 to T4, only progressive cavity pumps approved for use in category 1 (ZONE 0) may be used.
- Before each commissioning, check for external damage and for ease of movement.
- When using asynchronous motors, check the direction of rotation of the motor.
- In case of stationary use, check the direction of rotation again.
- When using the progressive cavity pump, all additional components attached to the connection part (coupling, motor, etc.) must be outside the tank.
- Before use, attach the equipotential bonding conductors to the progressive cavity pump, motor and container.
- Have the coupling and the carrier checked regularly and inspected for wear by qualified personnel.
- When using the pumps and motors in potentially explosive atmospheres, do not use motor adapters.
- No dry running.

#### 7.2.1.1 Explosion protection requirements

**Category 1 (ZONE 0)** The outer part of the progressive cavity pump between the suction opening and the discharge connection.

**Category 2 (ZONE 1)** The outer part of the progressive cavity pump between the discharge connection and the connection part for a motor and the inner part of the progressive cavity pump.  
When pumping is carried out as intended, the inner part is immersed in the pumped medium.

### 7.2.1.2 Establishing equipotential bonding

If the progressive cavity pump is operated with a motor in an Ex area, equipotential bonding is mandatory. Equipotential bonding must be established in the form of an electrically conductive connection between the motor and the progressive cavity pump in accordance with DIN EN 60079-0 and DIN EN 60079-14.

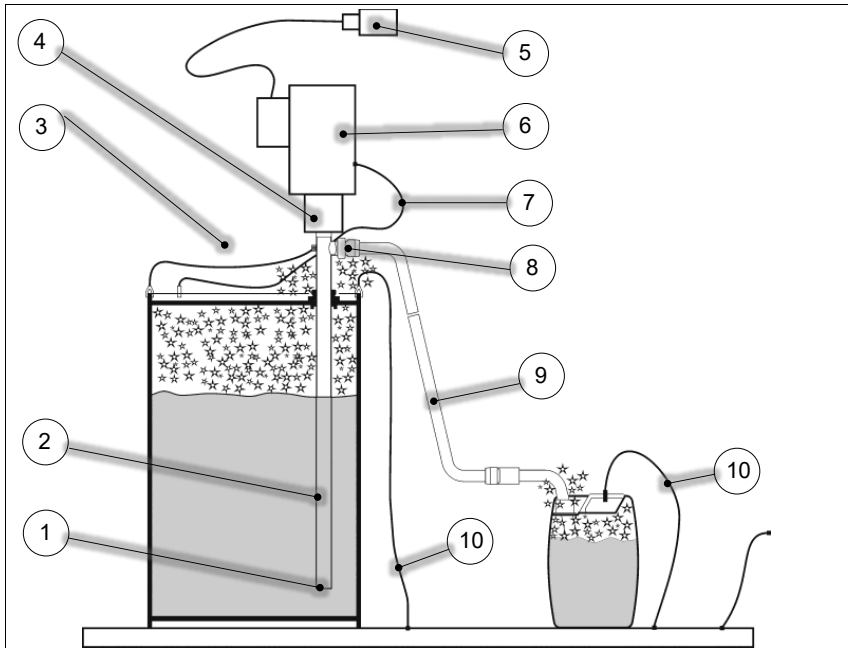

Figure 9: Equipotential bonding

Pos.	Meaning	Pos.	Meaning
1	Suction opening	6	Motor
2	Progressive cavity pump	7	Earth cable
3	Earth cable	8	Discharge connection
4	Motor connection	9	Hose line
5	Mains connection	10	Earth cable

### Proceed as follows

1. Secure the earth cable (3) to the dedicated screw at the explosion-proof pump tube.
2. Secure the earth cable (7) to the dedicated screw at the explosion-proof motor.

#### NOTICE

A conductive connection between the motor and the progressive cavity pump must be established as equipotential bonding in accordance with DIN EN 60079-0 and DIN EN 60079-14. If the motor is conductively connected to the progressive cavity pump (in the case of progressive cavity pumps for flammable media), only one of the two equipotential bonding conductors is required.

3. Earth both containers with one earthing cable each (10).

#### NOTICE

The hose line (9) connected to the discharge connection (8) of the drum pump must not exceed a resistance of  $10^6$  ohms between the hose ends. Only use with conductive hose fittings (see TRbF 50 Appendix B;  $R < 10^6 \Omega$ ). Earthing of a metal nozzle at the end of the hose is then not necessary.

4. Establish the mains connection (5) via an explosion-proof connector, an explosion-proof terminal box or outside the potentially explosive atmosphere.
5. To ensure good conductivity, remove any paint and dirt from the connection points of the equipotential bonding conductor and the transition points of the containers to the conductive base.

→ Equipotential bonding has been established.



#### NOTICE



The conductive base must be integrated into the equipotential bonding system. If there is no conductive base, equipotential bonding conductors must be connected to all containers.



## 8 Operation and use



The machine is started via the on/off switch on the motor. For more detailed information, please refer to the supplier documentation for the respective motor.



### 8.1 Safety

 <b>DANGER</b>	
	<p><b>Explosion and fire hazard</b></p> <p>Risk of death from explosions and fires when working in potentially explosive atmospheres.</p> <ul style="list-style-type: none"> <li>➤ Read chapter 2.4 <i>Working in potentially explosive atmospheres</i>.</li> </ul>

 <b>DANGER</b>	
	<p><b>Vapours hazardous to health</b></p> <p>Depending on the pumped medium, there is a risk of death due to hazardous gases.</p> <ul style="list-style-type: none"> <li>➤ Use respiratory protection.</li> <li>➤ Use eye protection.</li> </ul>

 <b>WARNING</b>	
	<p><b>Hot surfaces</b></p> <p>Depending on the pumped medium, there is a risk of burns on hot surfaces of the progressive cavity pump and peripherals.</p> <ul style="list-style-type: none"> <li>➤ Use heat-resistant hand protection.</li> </ul>

 <b>WARNING</b>	
	<p><b>Running shaft and running rotor</b></p> <p>Risk of cutting and injury from the running shaft and rotor.</p> <ul style="list-style-type: none"> <li>➤ Do not reach into the suction opening or the discharge connection of the progressive cavity pump.</li> </ul>



 <b>WARNING</b>	
	<p><b>Free-running drive shaft</b></p> <p>Risk of drawing in and injury due to free-running drive shaft of the motor.</p> <ul style="list-style-type: none"> <li>➤ Do not operate the motor without the progressive cavity pump!</li> <li>➤ Only switch on the machine if it has been properly installed in the peripherals.</li> </ul>



 <b>WARNING</b>	
<p><b>Unpredictable start-up of the motor</b></p> <p>Risk of injury due to medium spraying out.</p> <ul style="list-style-type: none"> <li>➤ Secure the motor against unintentional start-up.</li> <li>➤ Use eye protection.</li> </ul>	



- The following personal protective equipment must be used:
  - o Hand protection
  - o Protective footwear
  - o Eye protection (depending on the pumped medium)
  - o Hearing protection (depending on emission sound pressure)
  - o Respiratory protection (depending on the pumped medium)
- The machine may only be operated by qualified and authorised operating personnel.
- Make sure that the stop switch of the motor is accessible at all times.
- Only authorised personnel may work on the machine or be within its operating range. This also applies during standstill.
- Nobody may be present inside the danger area during work on and with the machine.
- Electrical and electronic assemblies are sensitive to moisture, dirt and temperature fluctuations.
- Fill in the media slowly and carefully to prevent it from splashing.
- Do not switch on the machine before it is in the medium.
- Use suitable splash guards for open drums or containers.
- Ensure sufficient ventilation of the container.
- Constantly monitor the machine during the pumping process.
- Monitor the pressure side for overpressure.
- Switch off the machine when no pumping is taking place.
- Allow the end of the hose to drip after the filling process (there may still be medium in the hose which then flows out unintendedly).
- Securely fasten the pump.
- For portable use, be sure to use a safe, explosion-proof carrying aid.



## 9 Help with faults

### 9.1 Safety

 <b>DANGER</b>	
	<p><b>Explosion and fire hazard</b></p> <p>Risk of death from explosions and fires when working in potentially explosive atmospheres.</p> <ul style="list-style-type: none"> <li>➤ Read chapter 2.4 <i>Working in potentially explosive atmospheres</i>.</li> </ul>

 <b>DANGER</b>	
 	<p><b>Vapours hazardous to health</b></p> <p>Depending on the pumped medium, there is a risk of death due to hazardous gases.</p> <ul style="list-style-type: none"> <li>➤ Use respiratory protection.</li> <li>➤ Use eye protection.</li> </ul>

 <b>WARNING</b>	
	<p><b>Hot surfaces</b></p> <p>Depending on the pumped medium, there is a risk of burns on hot surfaces of the progressive cavity pump and peripherals.</p> <ul style="list-style-type: none"> <li>➤ Use heat-resistant hand protection.</li> </ul>

 <b>WARNING</b>	
	<p><b>Running shaft and running rotor</b></p> <p>Risk of cutting and injury from the running shaft and rotor.</p> <ul style="list-style-type: none"> <li>➤ Do not reach into the suction opening or the discharge connection of the progressive cavity pump!</li> </ul>

⚠ WARNING	
	<p><b>Free-running drive shaft</b></p> <p>Risk of drawing in and injury due to free-running drive shaft of the motor.</p> <ul style="list-style-type: none"> <li>➤ Do not operate the motor without the progressive cavity pump!</li> <li>➤ Only switch on the machine if it has been properly installed in the peripherals.</li> </ul>

⚠ WARNING	
<p><b>Unpredictable start-up of the motor</b></p> <p>Risk of injury due to medium spraying out.</p> <ul style="list-style-type: none"> <li>➤ Secure the motor against unintentional start-up.</li> <li>➤ Use eye protection.</li> </ul>	

- The following personal protective equipment must be used:
  - o Hand protection
  - o Protective footwear
  - o Eye protection
  - o Hearing protection (depending on emission sound pressure)
  - o Respiratory protection (depending on the pumped medium)
- Troubleshooting may only be carried out by trained personnel.

## 9.2 Troubleshooting

The following table lists possible faults, their cause and suggestions for troubleshooting.

If a fault occurs, proceed as follows:

- Check if the fault is listed in the following table.
- Follow the instructions in the *Measure* column

NOTICE
<p>For the measures, the machine usually needs to be disassembled. See chapter 10 <i>Disassembly and cleaning</i>.</p>

## 9.2.1 Fault table

Table 17: Fault table

Fault	Cause	Measure
Medium leaks above the progressive cavity pump	Mechanical seal defective / worn	Replace the mechanical seal
	Mechanical seal not positioned correctly on counter ring	Grease the shaft surface on the sliding ring seat with suitable lubricant
Medium leaks between clamp connections	Seals on clamp connections missing or defective	Switch off the progressive cavity pump and check the seals
	Clamp connection insufficiently tightened	Switch off the progressive cavity pump and check the clamp connections
Medium leaking (mechanical seal)	Sliding ring not positioned correctly on counter ring	Grease the shaft surface on the sliding ring seat with suitable lubricant
No flow	Pump shaft broken	Replace the pump shaft
Insufficient flow	Stator or rotor heavily worn	Replace the rotor and/or stator
	Stator and rotor are not compatible	Check the compatibility between rotor and stator
Motor switches off (Overload)	Counterpressure too high	Reduce the counterpressure
	Blockage	Switch off the progressive cavity pump and remove the blockage
Motor running but progressive cavity pump does not pump	Pump shaft broken / rotor blocked	Replace the pump shaft
Motor running but progressive cavity pump does not pump (Asynchronous motor)	Motor running in the wrong direction. Due to the free-wheel, the progressive cavity pump cannot be driven in the wrong direction	Have the direction of motor rotation reversed by a qualified electrician
Motor does not start	Motor was overloaded	Let the motor cool down
	Mains cable/plug defective	Have the mains cable and plug checked by a qualified electrician
Progressive cavity pump vibrates strongly	Progressive cavity pump is running dry	Switch off the progressive cavity pump, check the fluid level
	Pump shaft is bent	Replace the pump shaft
Stator housing cannot be completely screwed onto pump tube	Stator not correctly positioned in stator housing	Position the stator in such a way that the lug of the stator housing engages in the groove of the stator



## 10 Disassembly and cleaning

For complete cleaning and replacement of components, the progressive cavity pump must be disassembled. Disassembly is almost identical for both the motor flange version and the gearbox version. Disassembly for cleaning is described below based on the motor flange version. Each disassembly step must be followed by cleaning the disassembled component. The progressive cavity pump must be cleaned after each use.

### NOTICE

During disassembly and assembly, the progressive cavity pump should be fixed with a vice with suitable half shells.

### 10.1 Safety

#### DANGER



##### Explosion and fire hazard

Risk of death from explosions and fires when working in potentially explosive atmospheres.

- Do not carry out disassembly in potentially explosive atmospheres.
- Read chapter 2.4 Working in potentially explosive atmospheres.

#### DANGER



##### Vapours hazardous to health

Depending on the pumped medium, there is a risk of death due to hazardous gases.

- Use respiratory protection.
- Use eye protection.



#### WARNING



##### Hot surfaces

Depending on the pumped medium, there is a risk of burns on hot surfaces of the progressive cavity pump and peripherals.

- Use heat-resistant hand protection.

- The following personal protective equipment must be used:
  - o Hand protection
  - o Protective footwear
  - o Eye protection (depending on the pumped medium)
  - o Respiratory protection (depending on the pumped medium)
- The progressive cavity pump may only be disassembled by qualified and authorised personnel.
- Before disassembly, remove the motor from the progressive cavity pump.
- All media must also be removed from the progressive cavity pump and properly disposed of before disassembly.
- Immerse the progressive cavity pump in a cleaning agent only up to the discharge connection.
- The power supply must be equipped with a residual-current circuit breaker.

## **10.2 Preparations**

- The following documents must be ready to hand before starting disassembly:
  - o Drawing of the progressive cavity pump
  - o Operating instructions of attachment parts – Supplier documentation
- Before starting disassembly, all components to be detached must be secured against falling, overturning or shifting.
- Have tools ready for disassembly.
- Provide suitable tools and aids such as assembly tools, spanners, vice and collection containers.
- Make sure that all operating substances have been drained.
- Before disassembly, empty the progressive cavity pump, hoses and fittings.

### **Tips for cleaning**

- Cleaning work must not be carried out inside the Ex-area.
- Do not use solvents over large areas, e.g. for degreasing.
- Observe material resistance.
- Do not use aggressive cleaning agents.
- Dispose of cleaning agents in accordance with applicable legal regulations.
- Observe the safety data sheets of cleaning agents.
- Do not use highly flammable or corrosive media for cleaning of the progressive cavity pump.
- Use suitable cleaning tools, e.g. a brush.
- Thoroughly rinse the individual components after cleaning and sterilise them if necessary.
- In case of adhesive and hardening media, flush the progressive cavity pump, then disassemble it and carefully clean the mechanical seal.
- Always carry out a visual inspection and function check after each cleaning operation.
- Carry out visual inspections, especially on internal threads and, in case of dirt, repeat cleaning with a suitable tool and check again.

### 10.3 Components

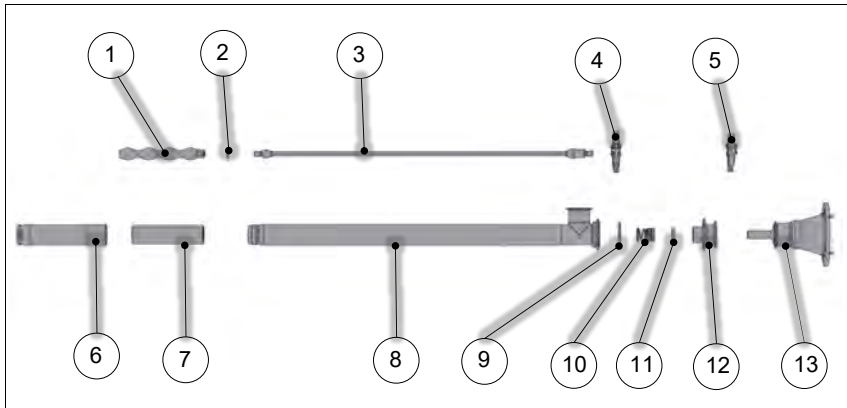

Figure 10: Components of the progressive cavity pump

Pos.	Meaning	Pos.	Meaning
1	Rotor	8	Pump tube
2	O-ring between rotor and pump shaft	9	O-ring between pump tube and seal carrier
3	Pump shaft	10	Mechanical seal (open)
4	Clamp connection between seal carrier and pump tube	11	Counter ring of mechanical seal
5	Clamp connection between seal carrier and motor connection	12	Seal carrier
6	Stator housing	13	Motor connection (motor flange)
7	Stator		

**Detaching the motor connection including pump shaft and rotor from the pump tube****NOTICE**

Carry out disassembly in a vertical position over a suitable container to prevent leakage of media. Even after emptying the pump tube, there is still medium between the rotor and the stator.

1. Loosen the clamp connection between the motor connection and the pump tube.

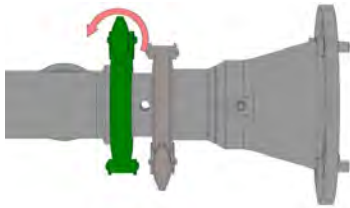

2. Pull the motor connection including pump shaft out of the pump tube.

**NOTICE**

If a pump shaft with a joint is installed, it folds down when it is pulled out.



3. Remove the O-ring at the upper opening of the pump tube.



→ The motor connection is now detached from the pump tube.

**Detaching the stator housing and stator from the pump tube**

1. Unscrew the stator housing from the pump tube (left-hand thread).

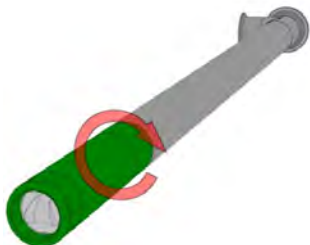

**NOTICE**

As an option to the screw connection between stator housing and pump tube, there is also a version with a clamp connection.

2. Remove the stator housing from the pump tube.



3. Manually push the stator out of the stator housing.



**NOTICE**

If the stator is stuck in the stator housing, the stator housing can be fixed in place using a vice with suitable half shells to carefully push out the stator with a suitable tool.

→ Disassembly for usual cleaning is now completed.

### Detaching the rotor from the pump shaft

#### NOTICE

If a rotor shaft is installed, the rotor cannot be disassembled from the pump shaft.

1. Unscrew the rotor from the pump shaft using two spanners (spanner size 18).



2. Remove the O-ring between pump shaft and rotor.



→ The rotor is now detached from the pump shaft.

### Detaching the motor connection from the pump shaft and exposing the mechanical seal

1. Turn the bearing shaft in such a way that the bore in the bearing shaft is aligned with the leakage openings.
2. Secure the bearing shaft in place with a suitable tool (e.g. 11-00000194 pinning tool) through the leakage opening.



3. Unscrew the pump shaft from the bearing shaft using a spanner (spanner size 24).

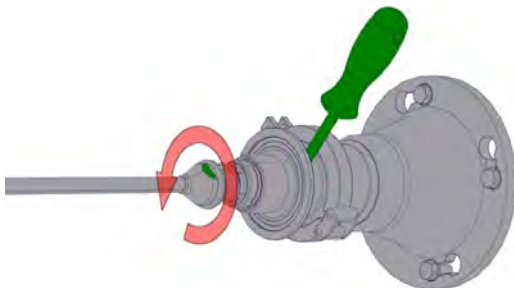

4. Remove the mechanical seal from the bearing shaft.

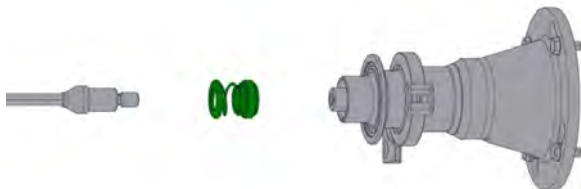

5. Loosen the clamp connection between the motor connection and the seal carrier.

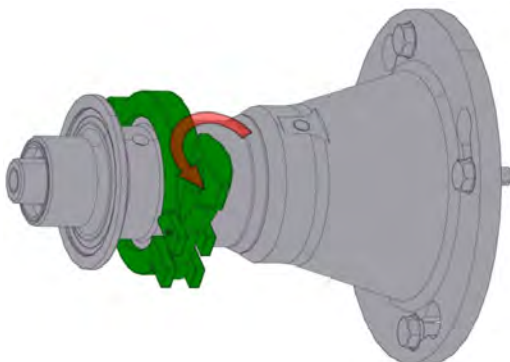

6. Remove the seal carrier from the bearing shaft.

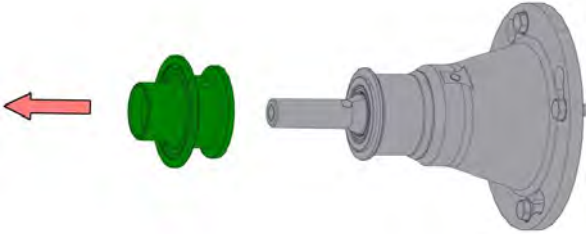

7. Push the counter ring of the mechanical seal out of the seal carrier from the drive side.

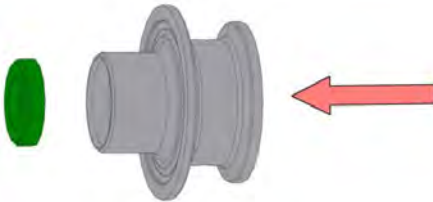

→ The mechanical seal is now completely exposed.



## 10.4 Assembly of the progressive cavity pump

### NOTICE

Assembly of the progressive cavity pump is done in reverse order of disassembly.

### NOTICE

For assembly between the stator housing and the stator, make sure that the groove of the stator is positioned in the lug of the stator housing.



### NOTICE

For assembly between the closed mechanical seal and the shaft, make sure that the pin of the closed mechanical seal is positioned in the groove of the shaft.



### NOTICE

Before reassembly, the fitting and sliding surfaces of the mechanical seal must be lubricated with a suitable lubricant.

### NOTICE

The lubricant must come into contact with the medium during pumping and must therefore be suitable for mixing and have the appropriate approvals (e.g. for food).

## 11 Maintenance and servicing

To reduce wear and tear and to avoid breakdowns and faults, prescribed maintenance and servicing must be carried out regularly in accordance with the maintenance schedule.

### 11.1 Safety

#### NOTICE

When repairing the progressive cavity pump, the motor must be removed.

#### NOTICE

Regularly check all motors in accordance with applicable and country-specific regulations and accident prevention regulations. See operating instructions for the respective motor.

#### DANGER



##### Explosion and fire hazard

Risk of death from explosions and fires when working in potentially explosive atmospheres.

- Read chapter 2.4 *Working in potentially explosive atmospheres*.

#### DANGER



##### Vapours hazardous to health

Depending on the pumped medium, there is a risk of death due to hazardous gases.

- Use respiratory protection.
- Use eye protection.

#### WARNING



##### Hot surfaces

Depending on the pumped medium, there is a risk of burns on hot surfaces of the progressive cavity pump and peripherals.

- Use heat-resistant hand protection.

 **WARNING**
**Running shaft and running rotor**

Risk of cutting and injury from the running shaft and rotor.

- Do not reach into the suction opening or the discharge connection of the progressive cavity pump!

 **WARNING**
**Free-running drive shaft**

Risk of drawing in and injury due to free-running drive shaft of the motor.

- Do not operate the motor without the progressive cavity pump!
- Only switch on the machine if it has been properly installed in the peripherals.

 **WARNING**
**Unpredictable start-up of the motor**

Risk of injury due to medium spraying out.

- Secure the motor against unintentional start-up.
- Use eye protection.

- The following personal protective equipment must be used:
  - o Hand protection
  - o Protective footwear
  - o Eye protection (depending on the pumped medium)
  - o Hearing protection (depending on emission sound pressure)
  - o Respiratory protection (depending on the pumped medium)
- Servicing and maintenance of the machine may only be carried out by qualified and authorised maintenance personnel.
- Before any maintenance, inspection and repairs, the machine must be taken out of operation.
- Maintenance and repair sometimes require that protective equipment be put out of operation or dismantled. After completion of maintenance and servicing, protective equipment must be immediately reinstalled and checked for proper function.
- Maintenance and servicing may only be carried out if the machine is at a standstill.
- Unsuitable operating and auxiliary substances can damage the machine. Only the specified operating and auxiliary substances may be used.
- Do not mix operating and auxiliary substances of different types and manufacturers. Only use the container approved and labelled for the respective operating substance.
- After maintenance and repair, retighten any loosened screw connections.
- Immediately replace any damaged machine parts with original parts.

- Make sure that electrical connections are not damaged.
- PTFE stators and the rotors are Ex-marked on the front. Only these may be used as spare parts.
- If the Ex symbol is no longer recognisable, the respective parts must be replaced.

## 11.2 Maintenance schedule

Component	Maintenance activity
O-rings	Regular visual inspection for wear
O-rings	Replace when worn
Mechanical seal	Regular visual inspection for wear
Mechanical seal	Replace when worn
Mechanical seal	Clean after each use
Progressive cavity pump	Visual inspection for leakage
Sliding surfaces of the mechanical seal	Lubricate after cleaning, before commissioning and after prolonged standing time (recommended grease: Klüber-synth UH1 14-151)
Fitting of the mechanical seal on the shaft	Lubricate after cleaning, before commissioning and after prolonged standing time (recommended grease: Klüber-synth UH1 14-151)
Coupling	Regular visual inspections for wear
Progressive cavity pump	Clean after each use
Hose clamps and hose fittings	Regularly check for secure fitting
Gearbox	Regularly check for ease of movement and absence of clearance and replace if necessary
Motor flange	Check bearings and freewheel regularly for ease of movement and absence of clearance and replace if necessary

---

## 12 Decommissioning

### 12.1 Safety

- The following personal protective equipment must be used:
  - Hand protection
  - Protective footwear
  - Eye protection (depending on the pumped medium)
  - Hearing protection (depending on emission sound pressure)
  - Respiratory protection (depending on the pumped medium)
- The machine may only be taken out of operation by qualified and authorised personnel.

## 13 Disposal

### 13.1 Information

- Dispose of the progressive cavity pump and associated components in accordance with national regulations.
- Any operating substances, in particular oil and grease, must be disposed of in accordance with national regulations and applicable safety data sheets.
- Disassemble the progressive cavity pump into transportable components.
- Collect media separately and dispose of it properly.
- Empty and properly clean tubing and containers.
- Properly dispose of any hazardous waste.

Disposal during maintenance and servicing is the responsibility of the operator.

**The following materials may require disposal:**

- Material residues
- Cleaning and maintenance products
- Consumables
- Waste of all kinds, including worn components
- Other waste

**For disposal of these materials, proceed as follows:**

- Collect any liquid waste as substances hazardous to groundwater (Water Resources Law) in approved containers and ensure proper disposal in compliance with applicable regulations.
- Ensure binding of any spilled or leaked media or soak them up immediately.

## 14 Lists

### 14.1 List of figures

Figure 1: Danger area .....	77
Figure 2: Wiring diagram (unactuated) .....	84
Figure 3: Type plate (symbol image) .....	85
Figure 4: Peripheral components (symbol image) .....	87
Figure 5: Components of the progressive cavity pump .....	88
Figure 6: Peripheral components (symbol image) .....	89
Figure 7: Components of the progressive cavity pump .....	90
Figure 8: Mechanical seals .....	91
Figure 9: Equipotential bonding .....	104
Figure 10: Components of the progressive cavity pump .....	113

### 14.2 List of tables

Table 1: Symbols .....	70
Table 2: Personal protective equipment .....	76
Table3: Typecode .....	79
Table 4: Marking – Identification .....	81
Table 5: Characteristics – Mechanics .....	81
Table 6: Characteristics – Mechanics .....	81
Table 7: Characteristics – Pumping capacity.....	81
Table 8: Characteristics – Operating and storage conditions.....	82
Table 9: Characteristics – Emission sound pressure.....	82
Table10: Materials .....	82
Table 11: Speed sensor – General information .....	83
Table 12: Speed sensor – Electrical data .....	83
Table 13: Speed sensor – Mechanical data .....	84
Table 14: Speed sensor – Thermal data .....	84
Table 15: Speed sensor – Connection .....	84
Table 16: Transport weight .....	92
Table 17: Fault table .....	110
Table 18: Applicable documents.....	126

## 15 Applicable documents

Table 18: Applicable documents

Designation/component	Manufacturer
Assembly sheet – Coupling on motor	FLUX-GERÄTE GMBH



# Anhang / Appendix / Annexe

**FLUX-GERÄTE GMBH**  
Talweg 12 · D-75433 Maulbronn



**EU Konformitätserklärung**  
**EU Declaration of Conformity**  
**Déclaration de Conformité UE**

Hiermit erklären wir,  
We,  
Nous,  
**FLUX-GERÄTE GMBH, Talweg 12, 75433 Maulbronn,**

dass die nachfolgend bezeichneten Produkte aufgrund ihrer Konzipierung und Bauart sowie in der von uns in Verkehr gebrachten Ausführung den einschlägigen grundlegenden Sicherheits- und Gesundheitsanforderungen der unten aufgeführten Richtlinien entsprechen. Bei einer nicht mit uns abgestimmten Änderung des Produktes verliert diese Erklärung ihre Gültigkeit.

hereby declare, that the following designated products comply with the pertinent fundamental safety and health requirements of the Directives mentioned below in terms of the design and construction and in terms of the version marketed by us. This declaration loses its validity in the event of a modification to the product not agreed with us.

déclarons par la présente, que les produits désignés ci-après répondent aux exigences fondamentales courantes en matière de sécurité et de santé des directives mentionnées ci-dessous aussi bien sur le plan de sa conception et de son type de construction que dans la version mise en circulation par nos soins. Cette déclaration perd sa validité en cas de modification du produit que nous n'avons pas approuvée

Bezeichnung des Produktes: Exzenterschneckenpumpen F 570 ...  
Description of the product: Progressive cavity pumps F 580 ...  
Désignation du produit : Pompes à vis hélicoïdale excentrée  
Serien - Nr.: siehe Typenschild am Gerät  
Serial no.: refer to nameplate on the device  
N° de série : voir plaque signalétique sur l'appareil

Bevollmächtigter für die Zusammenstellung der Technischen Klaus Bräuner,  
Unterlagen: FLUX-GERÄTE GMBH,  
Authorised person for the compilation of the technical documents: Talweg 12,  
Mandataire pour la constitution du dossier technique: 75433 Maulbronn

Qualitätsmanagementsystem: ISO 9001  
Quality Management system :  
Système de qualité :

Ex-Zertifizierung: PTB 97 ATEX Q004  
Ex Certification:  
Certification ADF :

Eingehaltene Richtlinien	Maschinenrichtlinie 2006/42/EG	ATEX Richtlinie 2014/34/EU		
Pertinent Directives	Machinery Directive 2006/42/EC	ATEX Directive 2014/34/EU		
Directive courantes	Directive Machines 2006/42/CE	ATEX Directive 2014/34/UE		
Angewandte harmonisierte Normen:	EN ISO 12100:2010	EN 809:1998+ A1:2009+AC:2010	EN 80079-36:2016	EN 80079-37:2016
Applied harmonised standards, in particular:				
Normes harmonisées appliquées en particulier :				
Typ / type				
F 570...	x	x		
F 580...				
F 570 ..Ex..	x	x	x	x
F 580 ..Ex..				

**FLUX-GERÄTE GMBH**  
Talweg 12 · D-75433 Maulbronn



Typ / Type	Benannte Stelle	EU-Baumusterprüfbescheinigung	Registriernr. / Ex-Kennzeichnung
	Notified Body	EU-Type-Examination Certificate	Registration no. / Ex marking
	Organisme notifié	Attestation d'examen UE de type	No. de registration / Marquage ex
F 570 „Ex.. F 580 „Ex..	PTB 0102, Bundesallee 100, 38116 Braunschweig	PTB 22 ATEX 5002 X	II 1/2 G Ex h IIB T4... T3 Ga/Gb

Datum / Hersteller - Unterschrift:  
Angaben zum Unterzeichner  
Date / manufacturer – signature  
Details of the signatory:  
Date / Signature du fabricant  
Renseignements du signataire :

  
12.10.2022 / FLUX-GERÄTE GMBH  
Klaus Hahn  
Geschäftsführer / Managing Director / Directeur



(1) **EU-TYPE EXAMINATION CERTIFICATE**  
(Translation)

(2) Equipment or Protective Systems Intended for Use in Potentially Explosive Atmospheres - **Directive 2014/34/EU**

(3) EU-Type Examination Certificate Number:

**PTB 22 ATEX 5002 X**

**Issue: 0**

(4) Product: Eccentric screw pump type F 570 „Ex.. (gearbox version), F 580 „Ex.. (motor flange version including coupling)

(5) Manufacturer: Flux-Geräte GmbH

(6) Address: Talweg 12, 75433 Maulbronn, Germany

(7) This product and any acceptable variation thereto is specified in the schedule to this certificate and the documents therein referred to.

(8) The Physikalisch-Technische Bundesanstalt, notified body No. 0102 in accordance with Article 17 of the Directive 2014/34/EU of the European Parliament and of the Council, dated 26 February 2014, certifies that this product has been found to comply with the Essential Health and Safety Requirements relating to the design and construction of products intended for use in potentially explosive atmospheres, given in Annex II to the Directive.

The examination and test results are recorded in the confidential Test Report PTB Ex 22-52108.

(9) Compliance with the Essential Health and Safety Requirements has been assured by compliance with:

**EN 80079-36:2016, EN 80079-37:2016**

(10) If the sign "X" is placed after the certificate number, it indicates that the product is subject to the Specific Conditions of Use specified in the schedule to this certificate.

(11) This EU-Type Examination Certificate relates only to the design and construction of the specified product in accordance to the Directive 2014/34/EU. Further requirements of the Directive apply to the manufacturing process and supply of this product. These are not covered by this certificate.

(12) The marking of the product shall include the following:

 **II 1/2 G Ex h IIB T4...T3 Ga/Gb**

Konformitätsbewertungsstelle, Sektor Explosionsschutz

Braunschweig, October 4, 2022

On behalf of PTB:

Dr.-Ing. M. Beyer  
Direktor und Professor



ZSE0001e c

sheet 1/3

EU-Type Examination Certificates without signature and official stamp shall not be valid. The certificates may be circulated only without alteration. Extracts or alterations are subject to approval by the Physikalisch-Technische Bundesanstalt. In case of dispute, the German text shall prevail.



## SCHEDULE

(13)

(14) **EU-Type Examination Certificate Number PTB 22 ATEX 5002 X, Issue: 0**

(15) Description of Product

The eccentric screw pumps are used for conveying low viscosity to high viscosity pasty and still free-flowing products from containers. Category 1 requirements apply within the container or pump, i.e. outer tube, shaft, shaft seal and rotor as well as stator of the pump. Category 2 requirements apply to all other parts of the eccentric screw pump.

(16) Test Report PTB Ex 22-52108

Based on the ignition hazard assessment of the manufacturer, the submitted test documents and measures for ignition source prevention of the eccentric screw pump type F 570 „Ex.. (gearbox version) and F 580 „Ex.. (motor flange version including coupling)“ were examined. Parts of the eccentric screw pump that conform with category-2 requirements, have not been re-examined and reassessed in connection with the above-mentioned Test Report (e.g. drive motor or coupling). These parts can be used if they have passed one of the Directive 2014/34/EU conformity assessment procedures that are prescribed by law and conform with the installation conditions. In connection with the Test Report, the category-1 parts, including sealing and bearing parts, and assembly with the already assessed parts (category 2), have been tested and assessed.

(17) Specific conditions of use

- The drive motors (operated electrically or with compressed air) must be selected so that they match the respective frame size with a torque of up to 20 Nm and a maximum idling speed together with the pump of 1,000 rpm.
- A motor protection device, including a starting lockout device shall be provided to prevent automatic starting, e.g. by starting the pump with a plug connector. For automatic filling, a motor with a motor protection device can also be used without a switch-on interlock.
- The line (hose or pipe) connected to the discharge port of the eccentric screw pump must not exceed a resistance of  $10^6 \Omega$  between the ends.
- Before the system is put into service, the eccentric screw pump must be included into the equipotential bonding system, i.e. equipotential bonding of the pump pipe with the tank (barrel), equipotential bonding of the motor with the tank (barrel) or the pump pipe, if the pump pipe and the drive motor are not conductively connected. The tank must be earthed separately, if earthing is not already provided with the type of installation.
- The maximum ambient temperature according to the operating instructions must not be exceeded.
- The maximum medium temperature according to the operating instructions must not be exceeded in the container.

sheet 2/3

EU-Type Examination Certificates without signature and official stamp shall not be valid. The certificates may be circulated only without alteration. Exchanges or alterations are subject to approval by the Physikalisch-Technische Bundesanstalt. In case of dispute, the German text shall prevail.



**SCHEDULE TO EU-TYPE EXAMINATION CERTIFICATE PTB 22 ATEX 5002 X, Issue: 0**

- The bearing / seals must be protected to prevent rare faults. These protective measures consist of filling the inside of the pump with liquid. Since the barrel pump is permanently monitored by an operating person, situations in which rare faults and an explosive atmosphere occur simultaneously can be excluded.
- The eccentric screw pump must never be left unattended when in operation. It must be prevented from running dry or idling.
- Due to the constant monitoring of the eccentric screw pump by an operating person during the pumping process, pumping against a closed shut-off device can be ruled out.
- For operation of the eccentric screw pump, all elements (coupling, drive motor, etc.), which are additionally installed at the connection unit, must be arranged outside the tank.
- Operation of the pump may lead to electrostatic charges in flowing liquids

(18) Essential health and safety requirements

Met by compliance with the aforementioned standards.

Konformitätsbewertungsstelle, Sektor Explosionsschutz

Braunschweig, October 4, 2022

On behalf of PTB

Dr.-Ing. M. Beyer  
Direktor und Professor





**UKCA Declaration of Conformity**

We, **FLUX-GERÄTE GMBH, Talweg 12, 75433 Maulbronn, Germany**, hereby declare,

that the following designated products comply with the pertinent fundamental safety and health requirements of the statutory instruments mentioned below in terms of the design and construction and in terms of the version marketed by us.

This declaration loses its validity in the event of a modification to the product not agreed with us.

General description: Progressive cavity pumps F 570  
F 580.

Serial no.: Refer to nameplate on the device

Authorised representative and authorised person for the compilation of the technical documents: FLUX Pumps Intern. (UK) Ltd.  
11 Enterprise Park  
Blackmoor Road  
Verwood, Dorset BH31 6YS  
Russell Morgan

Quality Management system: ISO 9001

Pertinent Directives	Supply of Machinery (Safety) Regulations 2008, 2008 No. 159 (as amended)	
Applied harmonized standards, in particular:	EN ISO 12100:2010	EN 809:1998+A1:2009+AC:2010
Type		
F 570 ... F 580 ...	X	X

Date, Place of Issue – signature  
Details of the signatory:

08.08.2022, FLUX-GERÄTE GMBH, Maulbronn  
Klaus Hahn, Managing Director



### Declaration of Conformity

For the materials and articles, which may come into contact with food when used as intended, FLUX-GERÄTE GMBH, Talweg 12, D-75433 Maulbronn hereby confirms the conformity with the general requirements of

Regulation (EC) No 1935/2004 of 27 October 2004 on materials and articles intended to come into contact with food.

This applies to the following types:

FP 427 S ... FOOD  
FP 430 Ex S ... FOOD  
F 560 S ... FOOD  
F 560 GS ... FOOD  
F 570 ... FOOD ...  
F 580 ... FOOD ...  
FMO 110 ... FOOD  
Follower plate VISCOFLUX system

For the materials and articles in contact with food applies also:

- Metal components are made of stainless steel (1.4301, 1.4305, 1.4404, 316 Ti or 1.4581).
- Elastomers meet the "Lebensmittel-, Bedarfsgegenstände und Futtermittelgesetzbuch" (LFGB, Food, Consumer Goods and Feed Code) of the Federal Republic of Germany and its implementation in the "Bedarfsgegenständeverordnung" (BedGstV, Consumer Goods Ordinance) and the recommendations XXI of the "Bundesinstitut für Risikobewertung" (BfR, Federal Institute for Risk Assessment) „Bedarfsgegenstände auf Basis von Natur- und Synthesekautschuk" (Commodities based on natural and synthetic rubber) and are FDA approved (CFR 21 Part 177.2600 - Food and Drugs).
- Plastics comply with the Regulation (EU) No. 10/2011 of 14th January 2011 on plastic materials and articles intended to come into contact with food and are FDA approved (CFR 21 Part 177.1550 - Food and Drugs). Used are:
  - Sliding rings made of carbon fiber reinforced PTFE
  - Stators made of PTFE
  - Bearing made of PTFE
  - Bearing housing made of PTFE
  - Ceramic components made of oxide ceramics

The items listed made of plastic are suitable for multiple contact with all food categories provided a contact time is not exceeded by 24 h and a contact temperature of 40 °C, including a brief heating to a maximum of 85 °C.

Maulbronn, 21.04.2022

FLUX-GERÄTE GMBH

A handwritten signature in blue ink, appearing to read "K. Hahn".

Klaus Hahn  
Managing Director



ISSUE DATE: April 14, 1995

CERTIFICATE AUTHORIZATION NUMBER: 828



THIS IS TO CERTIFY THAT

**FLUX-GERATE GMBH**

Talweg 12, 75433 Maulbronn , Germany

is hereby authorized to continue to apply the  
3-A Symbol to the models of equipment, conforming to 3-A Sanitary Standards for:

**Number 02-12**

**02-12 (Centrifugal and Positive Rotary Pumps)**

set forth below

COP Models: F560 S3A-50/21, F560 S3A-54/26, F560 GS3A-50/21, F560 GS3A-54/26, F560 S3A-54/26 TR, F570 3A and F580 3A.

CIP/COP Models: F427 S3A-43/38.

**VALID THROUGH: December 31, 2023**

Timothy R. Rugh  
Executive Director  
3-A Sanitary Standards, Inc.

The issuance of this authorization for the use of the 3-A Symbol is based upon the voluntary certification, by the applicant for it, that the equipment listed above complies fully with the 3-A Sanitary Standard(s) designated. Legal responsibility for compliance is solely that of the holder of this Certificate of Authorization, and 3-A Sanitary Standards, Inc. does not warrant that the holder of an authorization at all times complies with the provisions of the said 3-A Sanitary Standards. This in no way affects the responsibility of 3-A Sanitary Standards, Inc. to take appropriate action in such cases in which evidence of nonconformance has been established.

**NEXT TPV INSPECTION/REPORT DUE: December 2026**





IOM\_VISCOPOWER\_0223US

**FLUX-GERÄTE GMBH**

Talweg 12 · D-75433 Maulbronn  
Tel +49 7043 101-0 · Fax +49 7043 101-444  
info@flux-pumpen.de · www.flux-pumps.com

**FLUX PUMPS CORPORATION**

300 Townpark Drive, Suite 130  
Kennesaw, GA 30144, USA  
Phone 800-367-3589  
info@fluxpumpsusa.com  
www.fluxpumpsusa.com